



INSTALLATION MANUAL
VENGEANCE FRONT BUMPER
PRODUCT NUMBER: D665X
APPLICATION: 2024 FORD RAPTOR



IMPORTANT SAFETY GUIDE | Your safety and the safety of others is very important.

In order to help you make informed decisions about safety, we have provided the following warnings, safety precautions, installation instructions, and other important information to alert you to potential hazards that could hurt you or others.

Please do a job safety analysis before each task to identify potential hazards for your situation and remove/protect against them. Use own good judgment and take your time.

Check packaged materials immediately upon arrival to ensure that all listed parts are included and undamaged.

Read and understand all warnings, safety precautions, and instructions before installing this product.

SENSORS FIELD OF VIEW MAY BE ALTERED WITH USE OF THE REPLACEMENT BUMPER.

WARNINGS

- Failure to observe the following warnings and instructions provided in this manual could lead to severe injury and/or death.
- For professional installation only. Careless installation and/or operation can result in serious injury, death, and/or equipment damage. All liability for installation and use rests with the user or consumer.
- Fab Fours, Inc. only approves installing this product according to these written instructions with the hardware provided. Failure to install according to these instructions will invalidate the warranty. This includes, but is not limited to, using alternative installation methods, hardware, or materials.
- This product is for off road use only.

SAFETY PRECAUTIONS

- Always remove jewelry and wear eye protection.
- Always use extreme caution when jacking up a vehicle for work. Set emergency brake and use tire blocks. Locate and use the vehicle manufacturers designated lifting points. Use jack stands.
- Always use appropriate and adequate care in lifting components into place.
- Always ensure components will remain secure during installation and operation.
- Always wear safety glasses when installing this kit. A drilling operation will cause flying metal chips. Flying chips can cause serious eye injury.
- Always use extreme caution when drilling a vehicle. Always disconnect power before welding. Thoroughly inspect the area to be drilled (on both sides of material when possible) prior to drilling, and relocate any objects that may be damaged.
- Always use extreme caution when welding a vehicle. Thoroughly inspect the area to be welded (on both sides of material when possible) prior to welding, and relocate any objects that may be a fire hazard. When welding in a cab, make sure the interior surfaces are covered (e.g., welding blanket) and a fire extinguisher is at hand.
- Always use extreme caution when cutting and trimming during fitting.
- Always tighten all nuts and bolts securely per installation instructions.
- Always route electrical cables carefully. Avoid moving parts, components that become hot, and rough or sharp edges.
- Always insulate and protect all exposed wiring and electrical terminals.
- Perform regular inspections and maintenance on mounts and hardware.

TABLE OF CONTENTS

- 2 SAFETY / DISCLAIMER
- 3 TABLE OF CONTENTS
- 4 A MESSAGE FROM THE OWNER
- 5 GETTING STARTED
- 6 PROVIDED MATERIAL
- 8 INSTALLATION
- 15 CONTACT

A MESSAGE FROM THE OWNER



Fab Fours' was born out of a passion for customizing vehicles and a love of the outdoors. Our engineering team uses the latest 3D design software to turn new product ideas into reality. In our factory, designs come to life with the combination of cutting edge technology for metal cutting and forming and an American workforce that puts its' heart and pride into every product.

From design and manufacturing, to quality and delivery, Fab Fours' mission is to be the market leader for steel truck and jeep accessories. We make sure a quality product is delivered on time, more than expected, better than expected to our customers.

Enjoy your new Fab Fours product. Welcome to the family!

Greg Higgs

FOUNDER, FAB FOURS

GETTING STARTED

Before you begin the installation process of your new Fab Fours product, we suggest laying out all materials and parts on a pad or protective surface.

Failure to fully account for all components before beginning installation may leave vehicle immobile until part is acquired. Refer to the next pages as an inventory check.

PROVIDED MATERIALS



23386 - RAPTOR VENGEANCE FRONT



22352 - L BRACKETS QTY: 2



61784 - PLASTIC SHEET

61632 EPOXY QTY:2

REQUIRED TOOLS

- 10MM SOCKET WRENCH
- 13MM SOCKET WRENCH
- 15MM SOCKET WRENCH
- 21MM SOCKET WRENCH
- T27 STAR HEAD
- BODY PRY TOOL
- CUTTING TOOL
- 1/2" SOCKET WRENCH
- 5/8" SOCKET WRENCH

ASSISTANCE

We recommend two people perform the installation as items are heavy and may need to be held in place while installing.

ORGANIZATION

Disassemble the vehicle where you can catalog and store everything. We suggest labeling and bagging all the OEM bolts when removing from the vehicle. Failure to keep track of parts could lead to an inability to properly reinstall components.

HARDWARE KIT | 50501-HW

IDENTIFICATION NUMBER	COMPONENT DESCRIPTION	QTY
50501-HW	7/16"-14 X 1.25" YELLOW ZINC HEX HEAD BOLT, GRADE 8	6
50501-HW	7/16" YELLOW ZINC FLAT WASHER, GRADE 8	12
50501-HW	7/16" YELLOW ZINC LOCK WASHER, GRADE 8	6
50501-HW	7/16"-14 YELLOW ZINC HEX NUT, GRADE 8	6
50501-HW	5/16"- 18 X 1" YELLOW ZINC HEX HEAD BOLT, GRADE 8	3
50501-HW	5/16"-18 YELLOW ZINC HEX NUT, GRADE 8	3
50501-HW	5/16" YELLOW ZINC FLAT WASHER, GRADE 8	6
50501-HW	5/16" YELLOW ZINC LOCK WASHER, GRADE 8	3
50501-HW	¼"-20 X 1" YELLOW ZINC HEX HEAD CAP SCREW, GRADE 8	8
50501-HW	¼"-20 YELLOW ZINC HEX NUT, GRADE 8	10
50501-HW	¼" YELLOW ZINC FLAT WASHER, GRADE 8	20
50501-HW	¼" YELLOW ZINC LOCK WASHER, GRADE 8	10
50501-HW	¼"-20 X 1.25" YELLOW ZINC HEX HEAD CAP SCREW, GRADE 8	2
50501-HW	10-24 X 1/2", BLACK BUTTON HEAD BOLT 18/8SS	2
50501-HW	10-24 HEX NUT 18/8SS	2
50501-HW	#10 LOCK WASHER 18/8SS	2
50501-HW	#10 FLAT WASHER 18/8SS	2
50501-HW	BLACK NYLON PLASTIC PLUG	2

DISASSEMBLY & INSTALLATION

1. Unplug the wiring harness located on the passenger side frame behind the front bumper.
2. Use a 13mm socket wrench to remove the 6 bolts holding the skid plate on and remove the skid plate from the truck. Figure 1.



Figure 1

3. Use a 21mm socket to remove the 6 (3 per side) nuts holding the front bumper to the frame rails. Figure 2.



Figure 2

4. Carefully remove the sensors from the OEM bumper by pulling the sensors out of the housings and then pushing the housings out of the bumper. Be careful not to damage the sensors or the housings during removal. Note the location of each housing so it can be placed in the correct location in your new bumper. Figure 3.

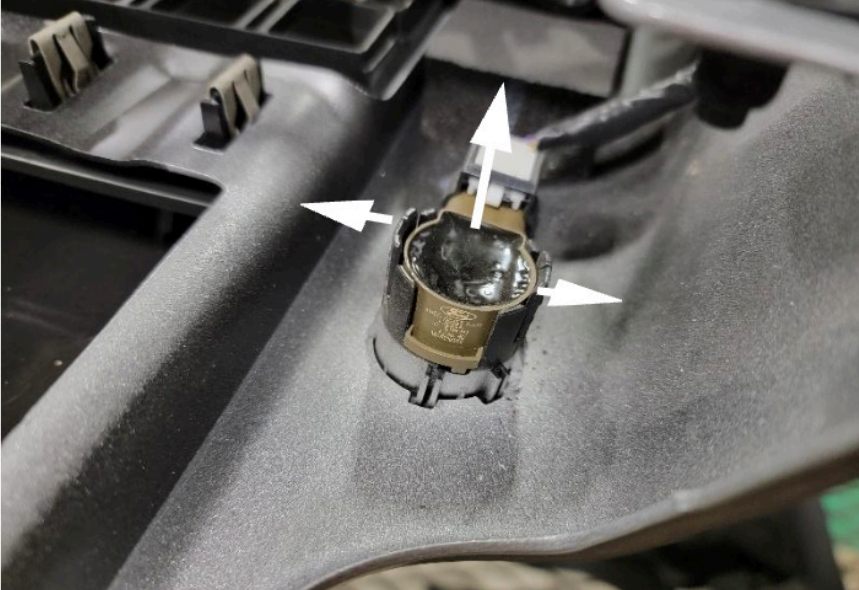

Figure 3

5. Place the housings into the new bumper and use the provided epoxy packets to fast them in place. Note orientation of the housings and make sure they are turned in the correct direction for the sensors and harness to fit. Figure 4.



Figure 4

-
6. Use a 10mm socket to remove the 4 hex head bolts holding the fog lights cover in the OEM bumper. Use a T27 star head socket to remove the 2 button head bolts holding the top of the fog light housing. Unplug the fog lights and remove the assembly from the truck. Figure 5.



Figure 5

7. Use a 13mm socket to remove the 5 bolts holding the driver side mounting plate onto the OEM bumper. Figure 6.



Figure 6

8. On the inside of the driver side mounting plate you will find the Adaptive Cruise Control (ACC) Sensor. Use a 10mm socket to remove the 3 bolts holding the ACC sensor to the mounts. Figure 7.

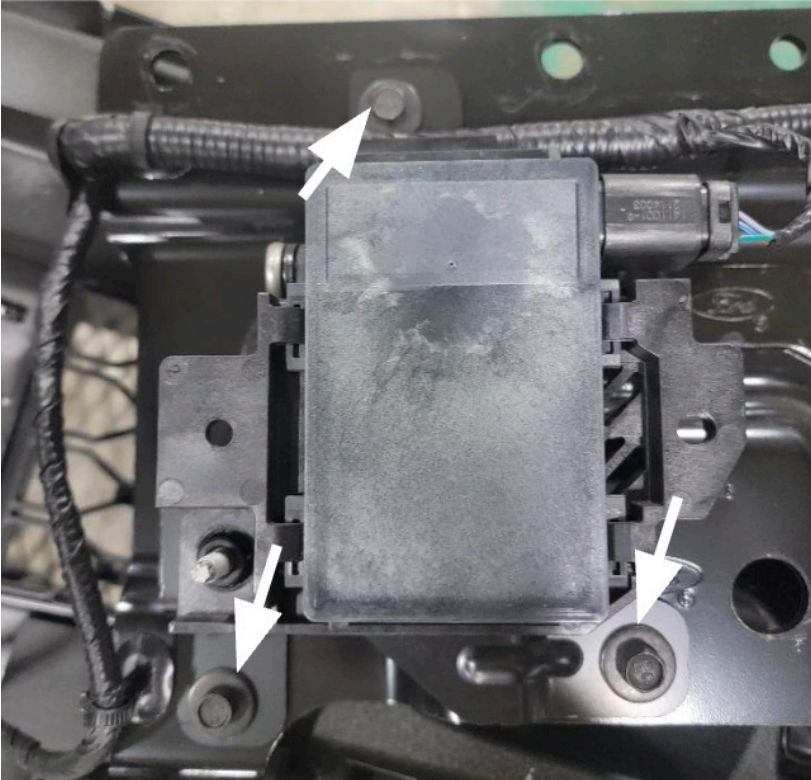

Figure 7

9. Use a cutting tool to trim the fog light housings along the bottom mounts and shown in Figure 8.

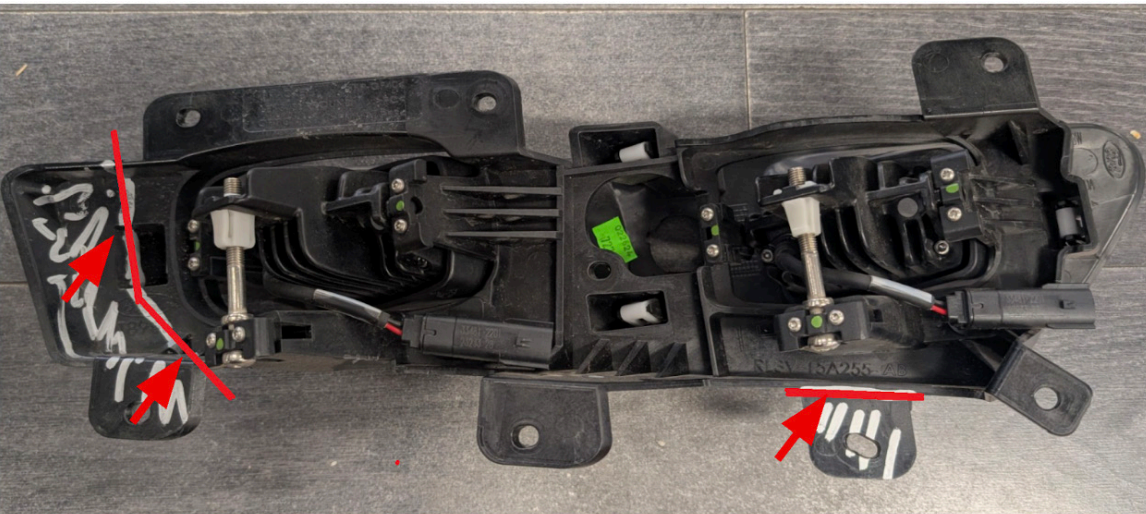

Figure 8

10. Place the fog light assembly into the Vengeance bumper and use 4x of the provided 1/4"-20 x 1" hex head bolts with washers and nuts to fasten it in place. Figure 9.

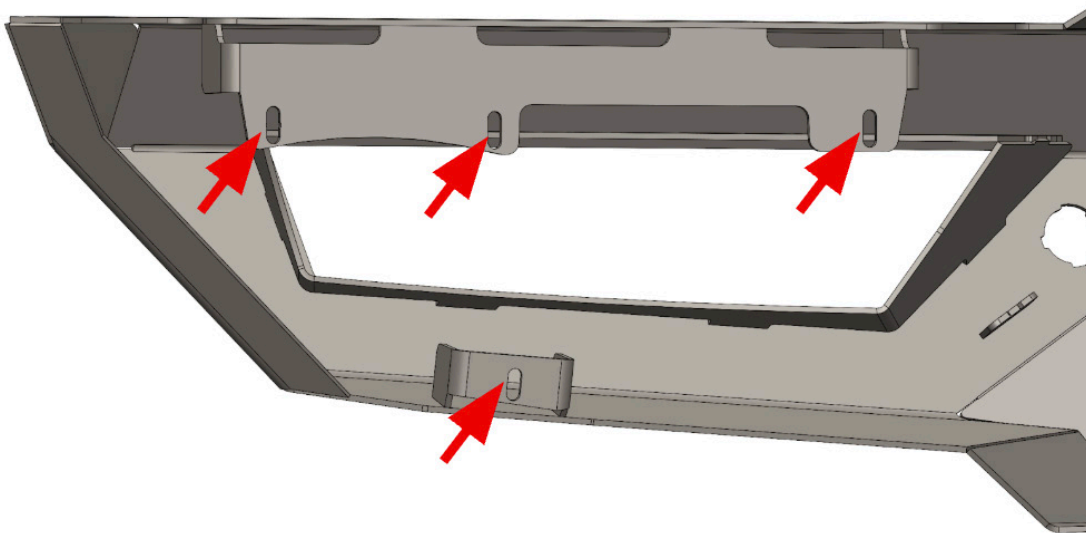

Figure 9

11. Cut the provided plastic sheet to the dimensions shown in Figure 11. Once cut hold the plastic sheet in the bumper over the ACC sensor cut out and use a sharpie to mark the bolts hole locations. Use a 5/16" drill bit to drill the marked mounting holes. Figure 10-11

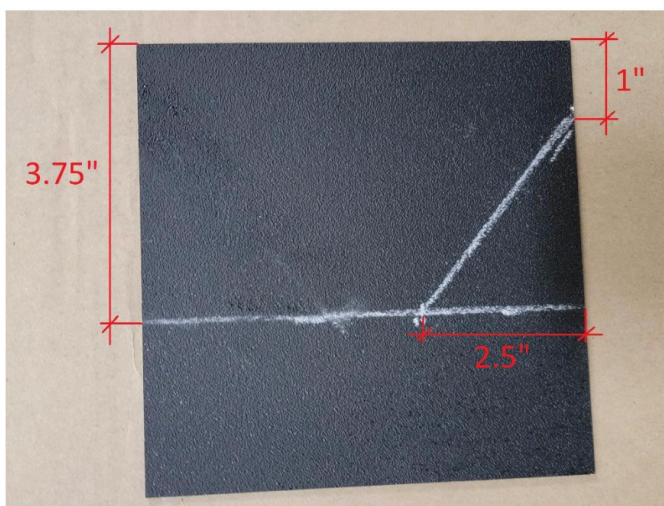

Figure 10

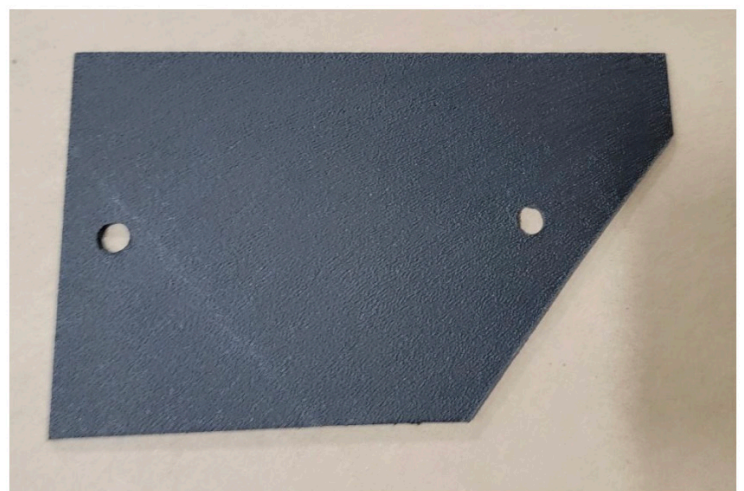

Figure 11

12. Use the provided #10 Black bolts, flat/lock washers, and nuts to fasten the plastic sheet into the bumper. Figure 12.

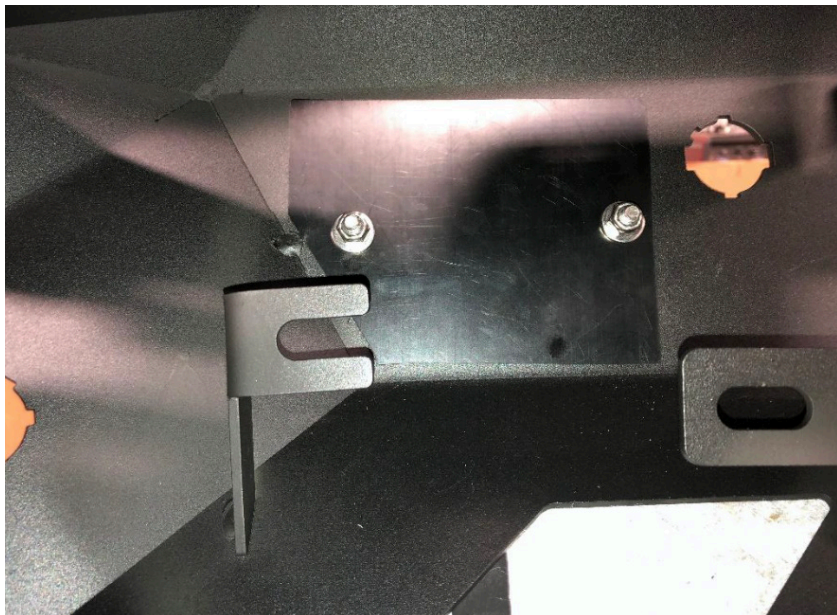

Figure 12

13. Use the provided 5/16" yellow zinc bolts, flat/lock washers, and nuts install the ACC sensor under the driver side mount. Tighten the ACC sensor in place. Figure 13.



Figure 13

14. If installing the 20" light bar, do so at this time using the integrated mounting points inside the bumper.

15. Run the OEM wiring harness through the bumper and plug in the parking sensors, fog lights, and ACC sensor. Make sure that the harness plug is located on the passenger side of the bumper. Note: you may have to undo some of the OEM conduit for the plugs to reach the fog lights and outside parking sensors.

16. With assistance, hold the bumper up to the frame and use the provided 7/16" yellow zinc bolts, flat/lock washers to fasten the bumper in place. Situate the bumper to your desired location and fully tighten all mounting hardware. Figure 14.



Figure 14

17. Plug the wiring harness in and reinstall the skid plate by reversing the step 2.

INSTALLATION COMPLETE

CONTACT INFORMATION

**FAB FOURS INC.
2213 INDUSTRIAL PARK ROAD
LANCASTER, SC 29720**

PHONE: (866) 385-1905

FAX: 970-385-1914

EMAIL: SUPPORT@FABFOURS.COM

FABFOURS.COM



**“IF YOU’RE LOOKING FOR MORE OF THE SAME,
THEN YOU’VE COME TO THE WRONG PLACE.”**

- GREG HIGGS

